

Ganzfeld ERG

On the web: <https://phoenixmicron.com>

Email us at: sales@phoenixmicron.com

The unique Maxwellian view design enables placing the corneal electrode on the front lens.

With an infrared camera for guidance, the electrode can be gently contacted to the cornea even in the dark, keeping absolute dark adaptation and stable contact with the eye.

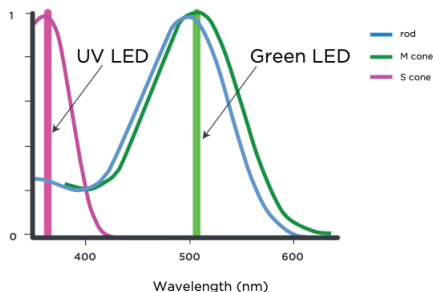
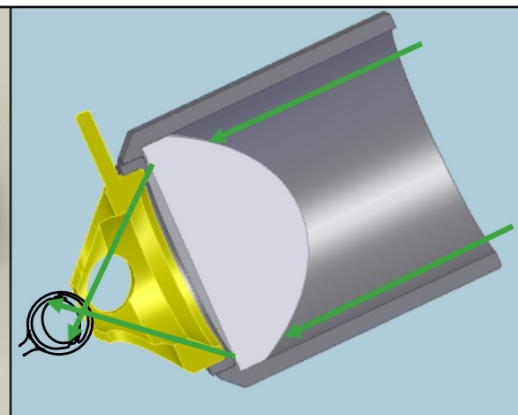

Measure responses:

The Phoenix MICRON Ganzfeld delivers both 505 nm and 365 nm to enable studies of both the cone and rod photoreceptors. The use of a single LED light source not only preserves bench space but also provides extraordinary flexibility in separately testing each of these photoreceptor classes. A near infrared (NIR) LED at 780 nm is used for pupil alignment. This is a wavelength where there is no response from the rodent retina, thereby maintaining the very best possible levels of scotopic adaptation.

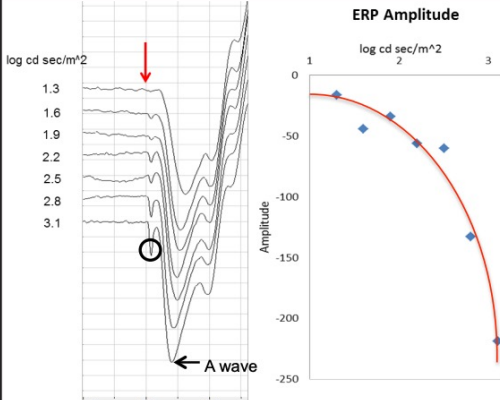
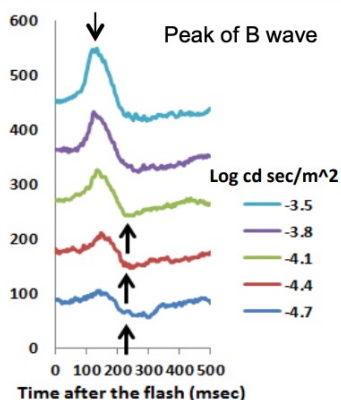

Scotopic Threshold Response (left) to Early Receptor Potential (right)





MICRON[®]

Ganzfeld ERG

On the web: <https://phoenixmicron.com> Email us at: sales@phoenixmicron.com

Maxwellian View Illumination

The Maxwellian view illumination technique focuses the light from a single LED onto the nodal point of the eye using a small F# lens diverging the light to illuminate the entire retina. This approach, with its compact size and use of LEDs, requires only 1 meter of lab bench space.



A wide variety of signal protocols are available

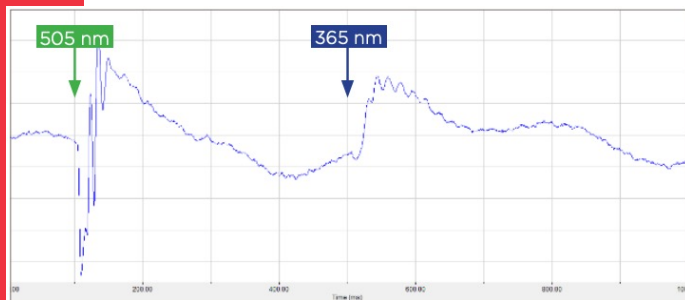

Double pulse, arbitrary wavelength selection

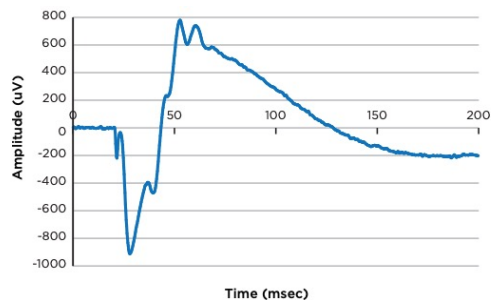

Sample ERG Waveform

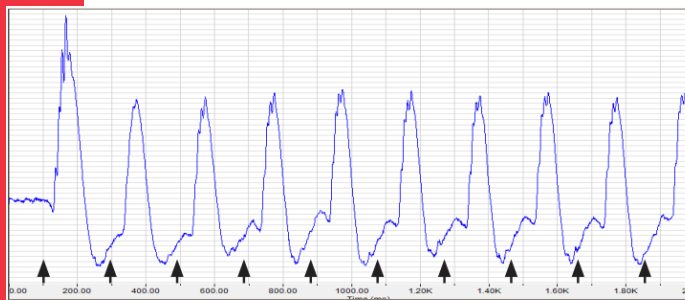

Flicker, arbitrary selection of frequency and background

1000+

Published papers that incorporate MICRON data

15+

Years of experience innovating patented small animal imaging technology

8

Imaging modalities, in a compact footprint

5

The latest generation MICRON Camera

2

Camera platforms





Ganzfeld ERG

On the web: <https://phoenixmicron.com> Email us at: sales@phoenixmicron.com

Specification	Details
Stimuli	365 nm and 504 nm
Illumination spot size	Full field
Range of stimulation in log cd sec/m ²	-4.7 to 3.1 Set levels over a range of 10 ⁸
Modes	Single flash Double/Flicker flash Alternate two-color flash Continuous background with flash Light adaption Chart mode
Pulse length	0.2 milliseconds to minutes
Objective lenses	Single objective lens for mice and rats
Pupil alignment	Illuminate at 780 nm for alignment
Electrodes	Corneal contact (gold-plated objective lens) Platinum needles for tail (ground) and head (reference)
Acquisition features	CLEAN mode to remove 60/50 Hz pickup noise; controllable bandwidth; controllable digitization sampling rate; control delay and pulse length for LED illumination
Analysis features	Automatic measurement of A and B wave peaks; automatic display of waterfalls; automatic measurement of OP peaks and implicit time; averaging with user selection
Camera	NIR to align pupil

