

The unique Maxwellian view design enables placing the corneal electrode on the front lens.

With an infrared camera for guidance, the electrode can be gently contacted to the cornea even in the dark, keeping absolute dark adaptation and stable contact with the eye.

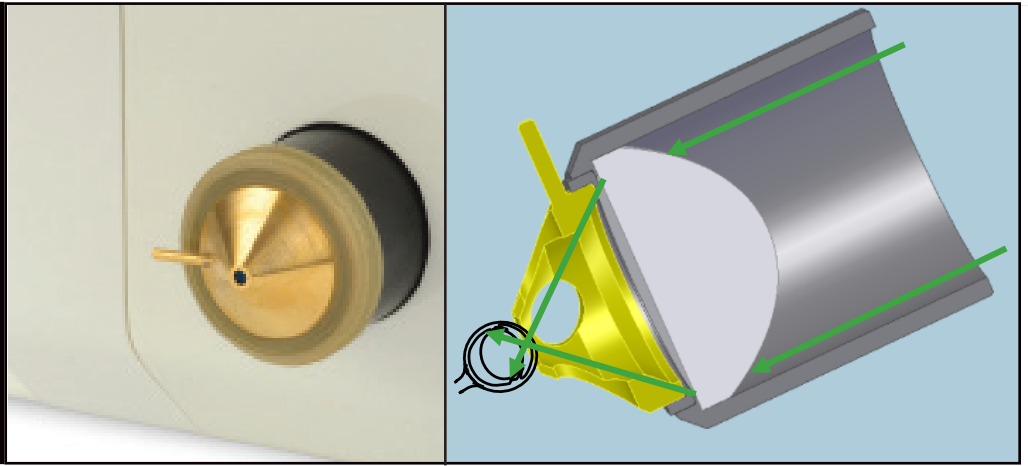

The Phoenix MICRON Ganzfeld ERG takes advantage of the Maxwellian view illumination technique to avoid the large size of the traditional bowl illumination approach. It is uniquely and specifically designed as a stand alone Ganzfeld for the rodent eye with the ability to test the function of retinal cells.

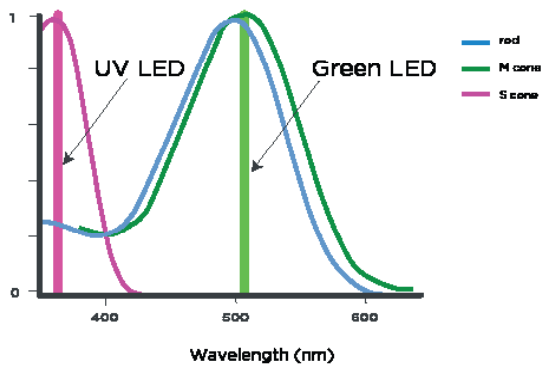

Measure responses:

The Phoenix MICRON Ganzfeld delivers both 505 nm and 365 nm to enable studies of both the cone and rod photoreceptors. The use of a single LED light source not only preserves bench space, but provides extraordinary flexibility in separately testing each of these photoreceptor classes. A near infrared (NIR) LED at 780 nm is used for pupil alignment. This is a wavelength where there is no response from the rodent retina, thereby maintaining the very best possible levels of scotopic adaptation.

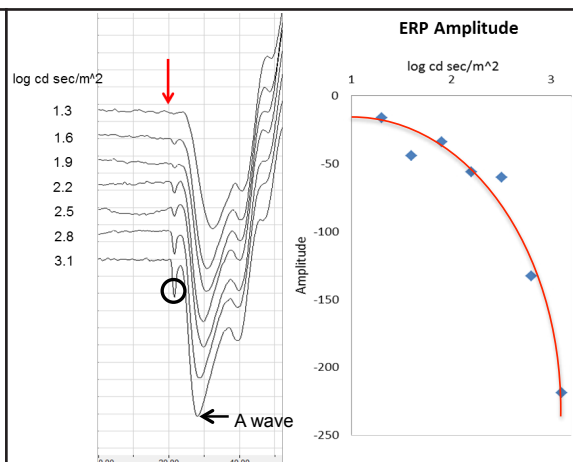
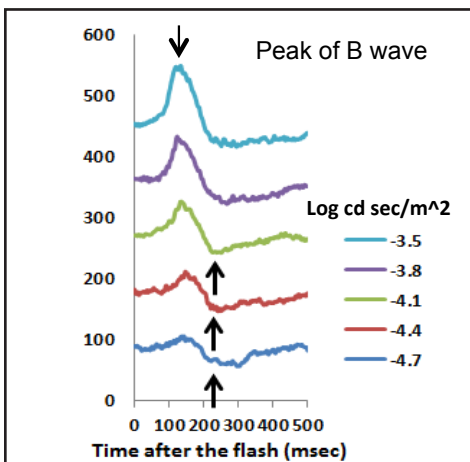

Scotopic Threshold Response (left) to Early Receptor Potential (right)

A wide variety of signal protocols is available through an intuitive interface

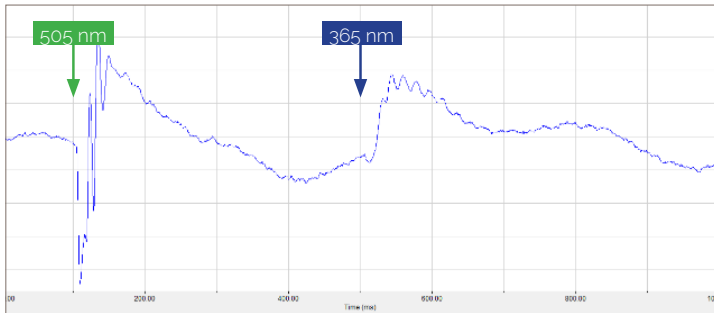

Double pulse, arbitrary wavelength selection

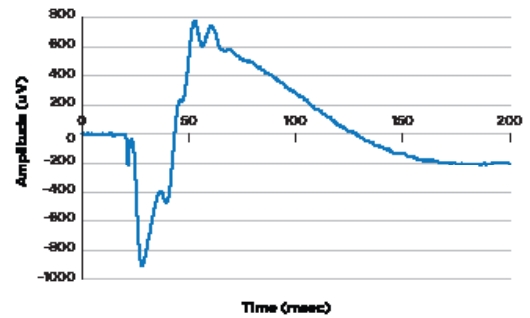

Sample ERG Waveform

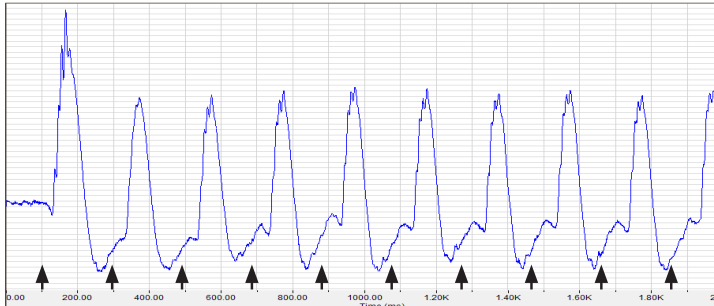

Flicker, arbitrary selection of frequency and background

Maxwellian View Illumination

The Maxwellian view illumination technique focuses the light from a single LED onto the nodal point of the eye using a small F# lens diverging the light to illuminate the entire retina. This approach, with its compact size and use of LEDs, requires only 1 meter of lab bench space.



Ganzfeld ERG

| | | |
|---|---|---|
| Stimuli | 365nm & 504nm | |
| Illumination size in diameter | Full field | |
| Range of stimulation in log cd sec/m ² | -4.7 to 3.1 Set levels over a range of 10 ⁸ | |
| Modes | Single flash Double/Flicker flash Alternate two-color flash | Continuous background with flash Light adaptation Chart mode |
| Pulse length | 0.2 millisecond to minutes | |
| Contact electrode | Single objective lens for mouse and rat | |
| Camera | NIR Camera to align pupil | |
| Heater | Maintain 37 degrees Celsius for Mouse and Rat | |
| Pupil Alignment | Pupil alignment at 780nm | |
| Software & Controls for Acquisition and Analysis | Acquisition: CLEAN* mode to remove 60/50 pickup noise Controllable Bandwidth Controllable digitization sampling rate Controllable scan and display time Controllable all parameters of LEDs (Delay, pulse length etc..) | Analysis: Automatic measurement of A and B wave peaks Automatic display of waterfalls Automatic measurement of OP peaks and implicit time Averaging with user selection Export data as CSV or text file |
| Animal stage | 5 planes of adjustment | |
| Electrodes | Corneal contact (gold-plate objective lens) Platinum needles for tail (ground) and head (reference) | |